

9400 Compact electronic on-board starter for Zenoah G230 RC
9405 Compact electronic on-board starter for Zenoah G2D96
9410 Compact electronic on-board starter for Zenoah G231 SLH

Important safety note:

Please note that a combustion engine with built-in electronic on-board starter is not a toy. The combustion engine may suddenly start by an unintentional "switching on". Please read the safety notes of the mounting instructions and additions carefully.

No new fan wheel is included for the on-board starter with stock number 9405 for Zenoah G2D96. In the case of this engine the coupling cramps of the removed fan wheel have to be refiled to the level of the fan blades. Thoroughly clean the fan wheel before mounting and make sure that there are no aluminium splinters inside the cone. Now remount the fan wheel. Instead of the bracket nut the extension nut 9405-01 is mounted (fig IV).

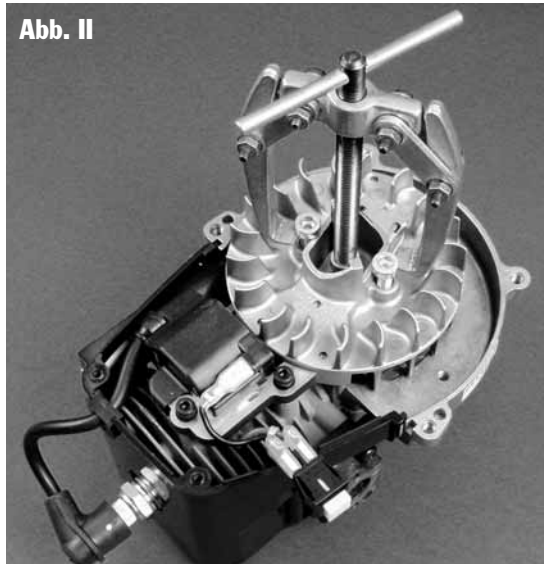

Hint

Apply some strong adhesive or locktite onto the flights of the extension nut to secure it (do not install a securing ring as this does not ensure concentric running). The following mounting of the on-board starter is almost identical for both engines.

General mounting instructions for Zenoah G230RC and Zenoah G2D96:

The Zenoah G230RC and Zenoah G2D96 engines are delivered fully equipped with cable starters. In order to install the electronic on-board starter you have to remove the cable starter, fan housing and fan wheel with the integrated coupling cramps (fig I and II).

Turn the screws M6x16 that are included in the kit into the fan wheel according to figure I. It is now possible to remove the fan wheel from the cone with every standard ball-bearing puller. Make sure that the wedge is not lost in the engine shaft (fig II).

In the case of the Zenoah G230RC you can now mount the reworked fan wheel that is included in the kit. Instead of the bracket nut the extension nut 9400/01 is mounted (fig III).

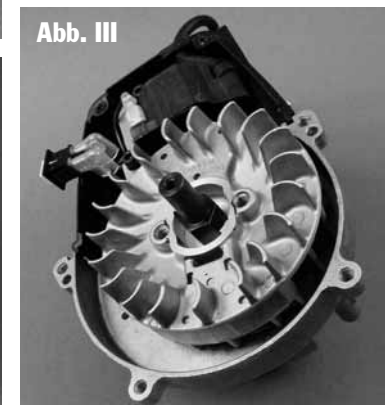
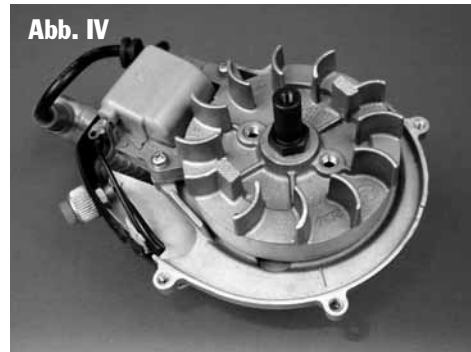

Mounting of freewheeling gear

To install the freewheeling gear see figure V. First put the check ring 9530-34 and the clamping ring 9530-24 onto the extension nut. The collar of the check ring shows into the direction of the combustion engine. Then install the freewheeling gear 9400-03 with the coupling 9400-02.

The freewheeling gear requires a slight axial clearance when mounted. It can easily be turned against starting direction but immediately engages when turned into starting direction.

The freewheel of the gear is pre-lubricated. Only the remaining side of the gearwheel has to be lubricated with the ball-bearing grease included in the kit. Make sure that no grease gets inside the cone of the coupling. The coupling is easily put into the freewheel by turning clockwise.

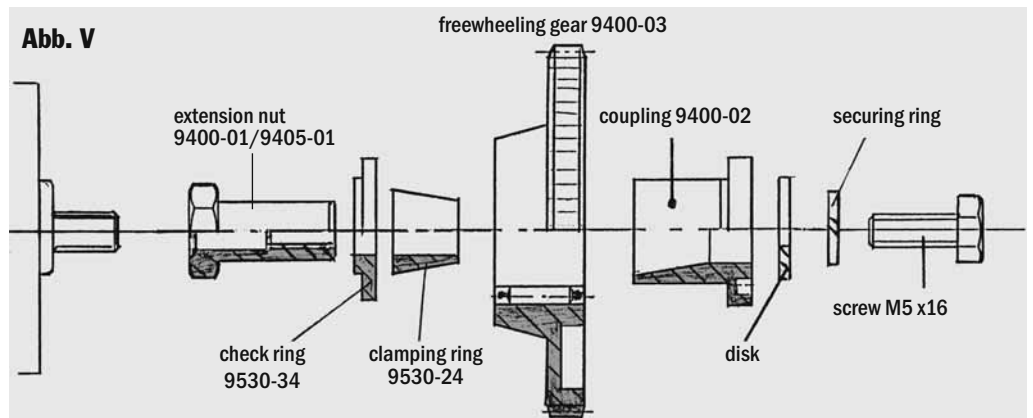

Hint

Before reinstalling the fan housing of the Zenoah G230RC file off ca 2 mm at the point ▼ (fig VIII) in order to give the pinion of the gear unit enough clearance.

Mounting of the electric motor

The next step is to screw together engine plate 9400/05 and gear plate 9400/06. Use short slotted-head screws M3x25, shaft plate 3.2 and nut M3. When screwed together it must be possible to turn the gearwheel with pinion easily. Then attach the electric motor with pinion (9400-04) with the included screws M2.5x8 plus securing ring and washer onto the engine bearing plate. When tightening the screws make sure that there is a slight clearance and that the gear can be turned evenly (fig VII).

Mounting of gear unit with electric motor on the fan housing

The Zenoah G230RC requires one washer 4.3/12x1 each between gear unit and stud. This is necessary in order to obtain the perfect distance to the freewheeling gear.

For the Zenoah G2D96 four distance bolts 4.3/8x10 mm have to be attached (fig VIII).

When tightening the screws make sure that there is a slight clearance. By manually turning the gearwheel in the first gear against starting direction you can check whether the complete starting unit can be turned evenly (see fig IX).

Abb. VI



Abb. VII



Abb. VIII



Spare parts Term	Stock number 9400	Stock number 9405	Stock number 9410
Extension nut	9400/01	9405/01	9410/01
Check ring	9530/34	9530/34	9530/54
Clamping ring	9530/24	9530/24	9530/24
Coupling	9400/02	9400/02	9400/02
Freewheeling gear	9400/03	9400/03	9400/03
electric motor with pinion	9400/04	9400/04	9400/04
Engine bearing plate	9400/05	9400/05	9410/05
Gear plate with pinion 10Z and Al gearwheel 66Z	9400/06	9400/06	9410/06
Set of small parts	9400/07	9405/07	9410/07
Micro-switch, 16A	9560/05	9560/05	9560/05
Airborne switch, 16A	9560/07	9560/07	9560/07
Two-cord cable 1.6 mm ²	9560/08	9560/08	9560/08
Reworked fan wheel	9400/08	not necessary	not necessary

Additionally required parts:

1 NC accumulator 9.6 Volt, min 0.7Ah, for Zenoah G230RC

1 NC accumulator 12 Volt, min 0.7Ah, for Zenoah G2D96

1 NC accumulator 9.6 Volt, min 0.7Ah, for Zenoah G231 SLH

4. Regulating of the electronic on-board starter via the radio control.

We recommend the following operational order:

As can be seen in the circuit schematic three switches which are connected in series are necessary for regulating the on-board starter. We recommend to install the airborne switch sunken. Thus it cannot be operated unintentionally.

Mark the on-off position of the switch clearly (fig I).

The safety switch additionally prevents from starting when the accelerator lever of the radio control is not idle running. The safety switch is operated by the throttle servo and is only closed in the position of idling. Keep the operational cams of the helm disk as short as possible (fig II).

The micro-switch for switching on and off of the electric motor is operated by the starter servo (fig III).

Recommendation for NC accumulator

The electric motor of the Zenoah G230RC requires a voltage of 9.6V and a minimum of 0.7Ah.

The electric motor of the Zenoah G2D96 requires a voltage of 12V and a minimum of 0.7Ah.

Highload NC accumulators only, as being used in electric model airplanes, are suitable for use as starter accumulator, i.e. Sanyo 800AR.

Max. starting time is 15 seconds to avoid a blow-out of the electric motor.

Putting into operation

Before putting into operation for the first time grease the gearwheels with a high-quality gear grease. The freewheeling is prelubricated. Prior to each flight operation use sewing-machine oil to lubricate the front ends only.

After having firmly tightened all screw connections make the first starting attempt. If the electric motor has the wrong direction of rotation interchange the electrical engine terminals.

Prior to starting for the first time the carburettor has to take in petrol via the attached bellows until petrol leaks out of the carburettor.

Now you can start the Zenoah with the electric on-board starter without difficulty. If the Zenoah is not starting immediately briefly put a finger onto the carburettor opening until the first ignitions occur. This procedure is required only once a flying day. As long as there is any fuel in the carburettor the engine is starting reliably.

Hints

If the freewheeling does not couple after a longer period of non-operation it is resinified in most of the cases. Clean it (fuel, spirit) and lubricate it with fine ball-bearing grease. During this cleaning process remove the gearwheel 9400-03 and coupling 9400-02 from the extension nut with

the help of a ball-bearing puller. Make sure that the rollers do not drop out of the freewheeling during cleaning. Dropped rollers can be inserted easily.

Warranty

Electric airborne starters are available as self-assembly kits. So correct installation and proper functioning is beyond our influence. That is why our warranty is limited to the components of the kits and their functioning. We do not assume liability for any damages resulting from improper installation or operation.

We wish you many successful takeoffs - and the same number of happy landings.

Abb. X

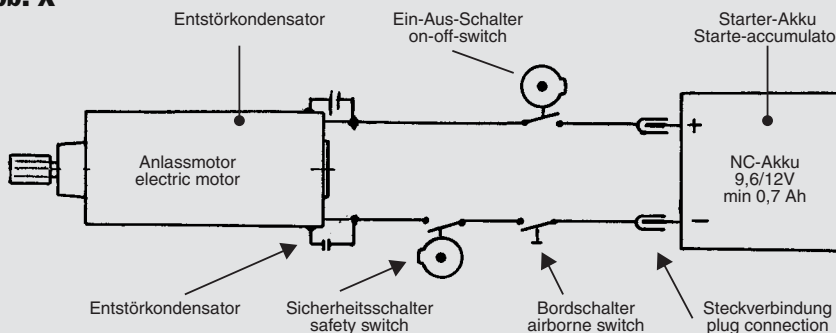

Fig. I Bordschalter
airborne switch

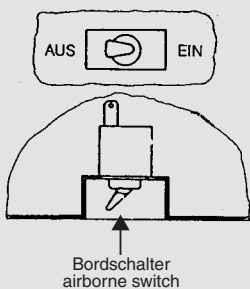

Fig. II Sichterheitsschalter
safety switch

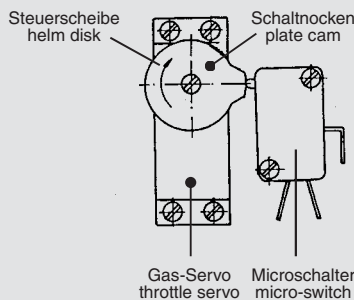
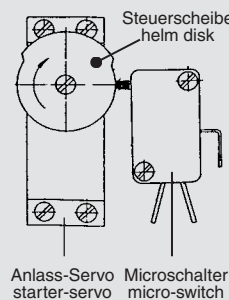

Fig. III Ein-Aus-Schalter
on-off-switch



For this function we recommend to use an IC servo with mounted reversion switch (i.e. Graupner C508 with reversion switch stock number 3945).

Mount the NC accumulator and the switches closely to the combustion engine. Make sure that the cables between NC accumulator, safety switch, on-off-switch and starter engine are as short as possible. They should have a minimal distance of 100 mm to receiver and antenna in order to avoid radio interferences. For wiring we recommend to use soldered junctions (plug connections cause an unnecessary transfer resistance). Tin the flexible wires prior to soldering them! After cooling check each soldered connection by shaking it. The NC accumulator is connected via high-quality plugs.

The electric motor eliminates all radio interferences.